

M SERIES

M-16A M-20A

M SERIES SPECIFICATIONS		M - 16A		M - 16P		M - 20A		M - 20P	
CAPACITY 90°	Rectangular Round	16' x 25' 16"	406 x 635mm 406mm	16' x 25' 16"	406 x 635mm 406mm	20' x 30' 20"	508 x 762mm 508mm	20' x 30' 20"	508 x 762mm 508mm
CAPACITY 45°	Rectangular Round	15' x 16' 16"	381 x 406mm 406mm	15' x 16' 16"	381 x 406mm 406mm	19' x 20' 20"	483 x 508mm 508mm	19' x 20' 20"	483 x 508mm 508mm
CAPACITY 60°	Rectangular Round	9' x 16' 11"	229 x 406mm 279mm	9' x 16' 11"	229 x 406mm 279mm	12' x 20' 14"	305 x 508mm 356mm	12' x 20' 14"	305 x 508mm 356mm
BLADE	Blade Dimensions	18' 6" 1 1/4"	5638mm 32mm	18' 6" 1 1/4"	5638mm 32mm	20' 6" 1 1/2"	6248mm 38mm	20' 6" 1 1/2"	6248mm 38mm
	Blade Drive	7.5 hp	5.5kW	7.5 hp	5.5kW	10 hp	7.5 kW	10 hp	7.5 kW
	Blade Wheel Diameter	19"	483mm	19"	483mm	22"	559mm	22"	559mm
	Blade Speed	50-350 SFM (vfd)	15-107 m/min	50-350 SFM (vfd)	15-107 m/min	50-350 SFM (vfd)	15-107 m/min	50-350 SFM (vfd)	15-107 m/min
OVERALL	Shuttle Stroke	0-33"	0-838mm	n/a	n/a	0-33"	0-838mm	n/a	n/a
	Hydraulic Drive	3 hp	2.2kW	3 hp	2.2kW	3	2.2kW	3	2.2kW
	Coolant Tank Capacity	9 US Gal	35 litres	9 US Gal	35 litres	9 US Gal	35 litres	9 US Gal	35 litres
	Table Height	32"	813mm	32"	813mm	32"	813mm	32"	813mm
	Machine Weight	7,400 lbs	3357 kg	7,200 lbs	3266 kg	7,700 lbs	3493 kg	7,500 lbs	3402 kg
	Machine Dimensions	Width Length Height	132" 90" 66"	3353mm 2286mm 1676mm	132" 90" 66"	3353mm 2286mm 1676mm	140" 90" 66"	3556mm 2286mm 1676mm	140" 90" 66"

In line with HYD•MECH's policy of on-going product improvement, we reserve the right to modify features and specifications. Note that some options may not be available or are standard on the CE machines. Please check with your dealer for option availability.

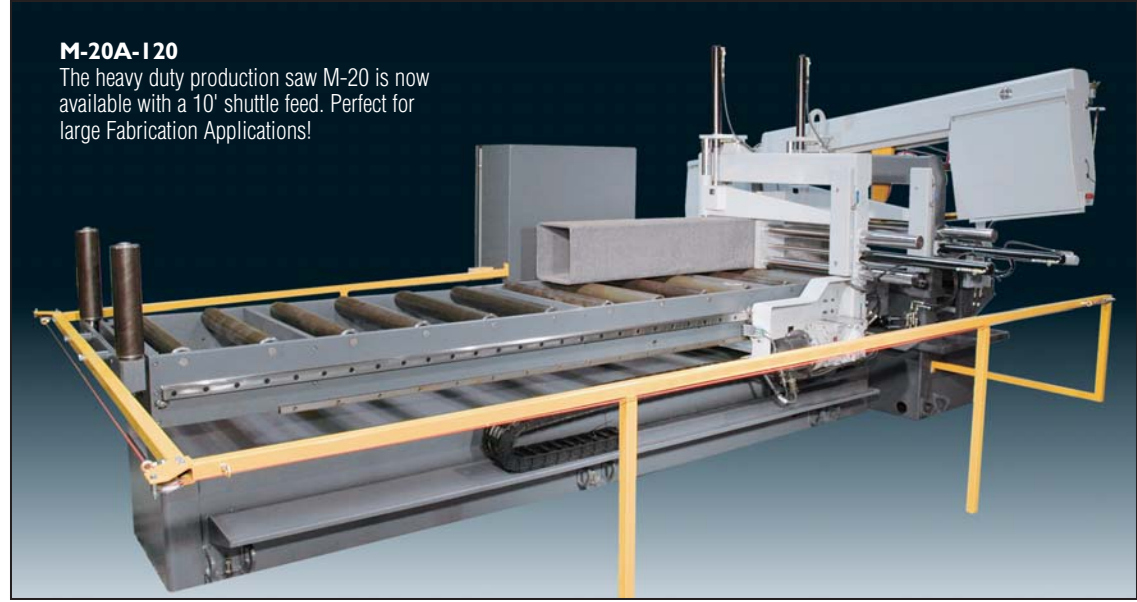

M-20A-120
The heavy duty production saw M-20 is now available with a 10' shuttle feed. Perfect for large Fabrication Applications!

Our Rock Solid Pledge promises you the best cost-per-cut solution, the latest in design and engineering technologies, only high quality components and excellent customer service for your Hyd•Mech sawing system.



HYD•MECH

The Rock Solid Solution.

HYD•MECH
The Rock Solid Solution.

HYD•MECH GROUP LIMITED
P.O. Box 1030, 1079 Parkinson Road, Woodstock, Ontario, Canada N4S 8A4
toll free: 1-877-276-SAWS(7297) phone: (519) 537-2103 fax: (519) 539-5126
www.hydmech.com email: info@hydmech.com

DEALER:

M SERIES

STANDARD FEATURES:

- 60° miter capability
- Heavy-duty full stroke vises
- Cast iron guide arms and wheels with a rigid pivot point
- Powered chip brush
- Carbide guides for longer blade life
- Chip auger
- Coolant pump for blade lubrication and wash down hose
- Heavy-duty motor and gearbox with variable frequency drive system
- Head up limit switch

OPTIONAL:

- Hydraulic overhead bundling
- PLC500
- Variable vise pressure
- Digital angle display
- Laser beam light
- Mist coolant system
- 5' and 10' conveyor tables



Note:
Photos may show optional equipment.

The M-Series...

The HYD•MECH M-Series represents the ultimate in production cutting in a fabricating environment. From its versatile swing head and user-friendly operator controls, the M-Series is solidly built to give you maximum productivity and the best cost-per-cut performance in its class.

M-16A
(Back View)

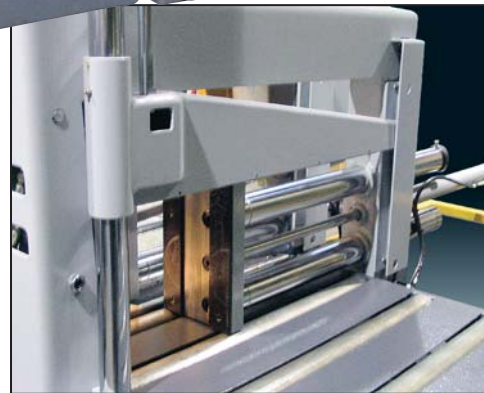

In a Class of their own!

The M-Series features a powerful motor and gearbox with variable frequency drive to provide exceptional cutting performance on a variety of material. The automatic models come standard with an easy to follow PLC100 or you can upgrade to the PLC500 controller, as shown in photo. The PLC500 enables the operator to program up to 99 jobs with 5 jobs in queue, including piece count, piece length and angle of cut.

PLC 500



Hydraulic Feed System

The downfeed system with feed rate and feed force is easily adjusted using the dials on the front control panel. A head fast approach function is also included.



Programmable Controller

The automatic models feature a PLC100 controller for manual or automatic operation. Program up to 99 jobs, with piece length and piece count and 10 jobs in queue.



Guides and Coolant

Heavy-duty guide arms with carbide guides help reduce vibration and extend blade life. Flexible coolant hose delivers coolant directly to blade for optimum lubrication.

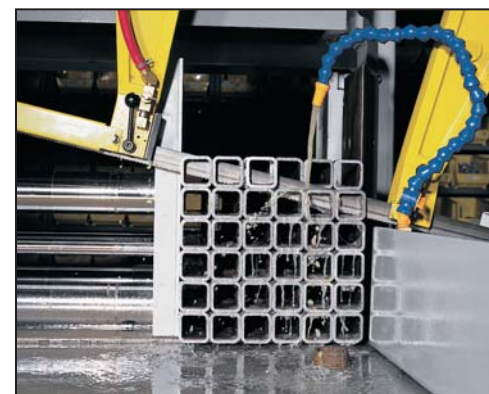

Hydraulic System

The M-Series hydraulic system is conveniently located on a swing front door panel with a clean layout for ease of maintenance.



Drive System

M-Series features a powerful gearbox and motor assembly with a reliable variable frequency drive system.

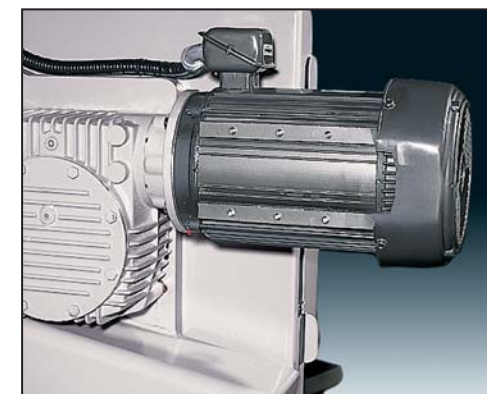

Pivot and Auger

Cast iron wheels and an oversized pivot provide extra rigidity. Powered chip brush keeps blade clean while chips are conveniently removed using the hydraulic chip conveyor.

